

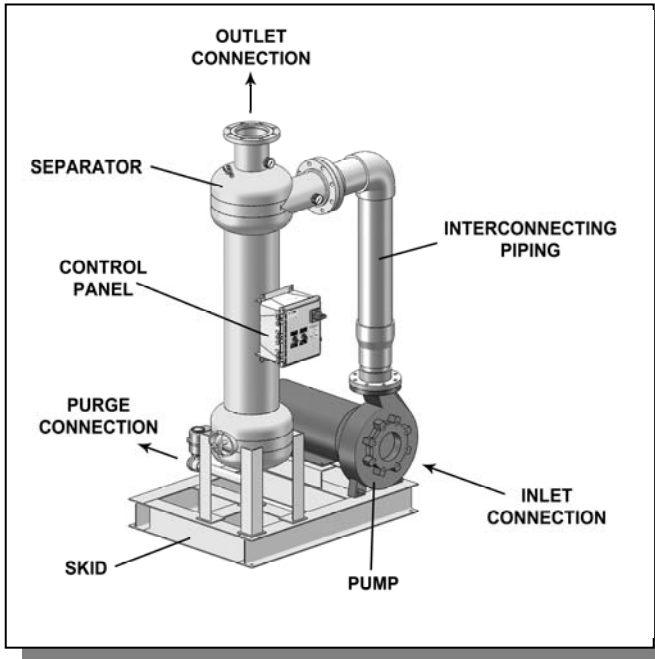

PF64-040(B) SPECIFICATION SHEET PUMP PACKAGE SYSTEM



| SPECIFICATIONS | PF64-040(B) |
|--------------------------|-------------|
| Flow Rate | 400 gpm |
| System Inlet Connection | 4" flng |
| System Outlet Connection | 4" flng |
| Purge Connection | 1 1/2" fpt |
| Separator Model | PF61-040 |
| Separator Purge | Automatic |
| Pump Motor | 10 hp |
| Volume | 15 gal |
| Est. Weight, Dry | 794 lbs |
| Est. Weight, Operating | 921 lbs |

- Removes particulate as low as 45 microns
- 150 psi working pressure

- Fully assembled skid package
- One year limited warranty

SYSTEM COMPONENTS

Separator :

- PF61-040 - 4" flanged separator
- Fusion bonded polyester coated vessel
- 1/4" Manual air bleed valve
- 0 to 160 psi gauges on influent / effluent

Electrical Controls :

- NEMA 4X fiberglass enclosure
- Motor overload/short circuit protection
- Hand-Off-Auto switches

Pump :

- Close coupled, end suction centrifugal pump
- 3450 rpm, TEFC motor

Automatic Purge :

- Electrically actuated industrial grade ball valve
- Adjustable purge timer

Skid :

- Fusion bonded polyester coated carbon steel

Interconnecting Pipe :

- Sch.80 PVC piping

Options: Cast Iron Pump Pre-Strainer, Manual Purge, Removable Dome, 22 1/2" profile

NOTES: UNLESS OTHERWISE SPECIFIED

1. DIMENSIONS ARE IN INCHES
2. DIMENSIONS MAY VARY SLIGHTLY - DO NOT USE FOR CONSTRUCTION
3. SEPARATOR SYSTEM IS RATED FOR 150 PSI WORKING PRESSURE
4. UNIT AVAILABLE WITH OPTIONAL PUMP PRE-STRAINER

| REVISIONS | | | |
|-----------|-------------|------|----------|
| REV | DESCRIPTION | DATE | APPROVED |
| - | | | |

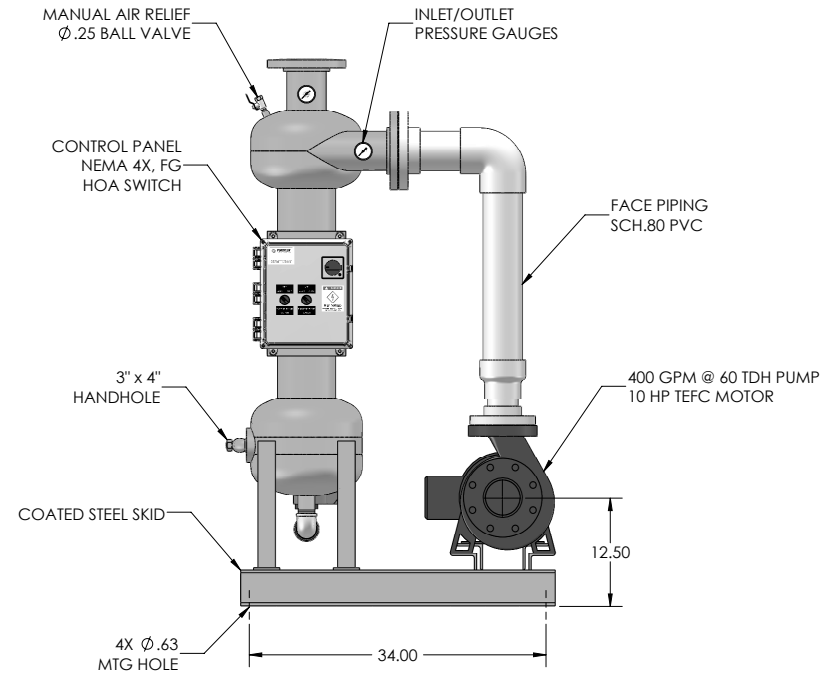
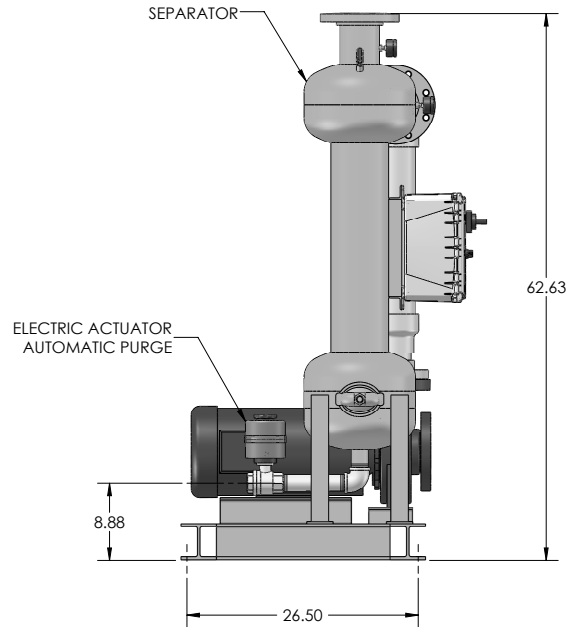
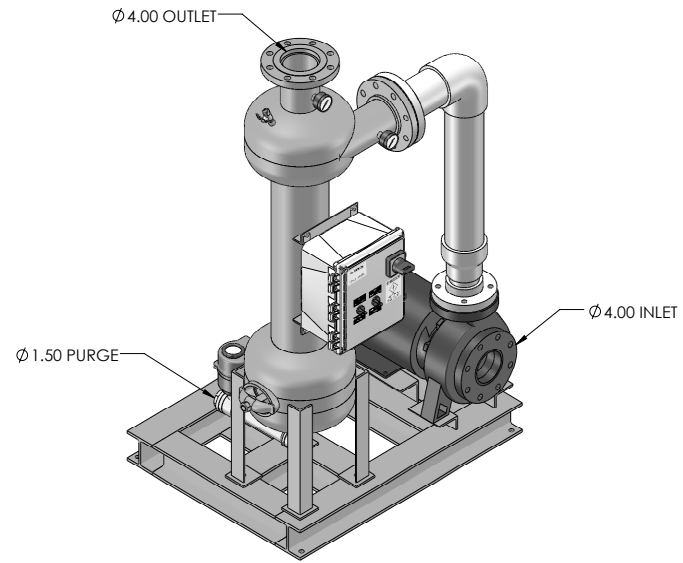
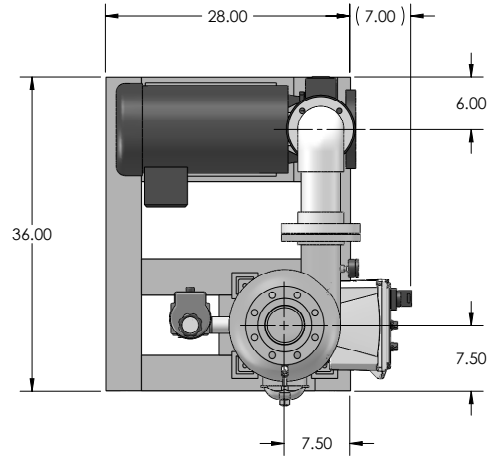

| | | | | |
|---|--|---------------------------|--|--|
| UNLESS OTHERWISE SPECIFIED DIMENSIONS ARE IN INCHES TOLERANCES: FRACTIONAL ± ANGULAR: MACH ± BEND ± TWO PLACE DECIMAL ± THREE PLACE DECIMAL ± | | PROJ. NO. | PF-64-040(B) AP SEPARATOR PACKAGE 400 GPM - W/SKID MOUNTED PUMP | |
| INTERPRET GEOMETRIC TOLERANCING PER: | | DRAWN | D. LUNA | |
| MATERIAL | | CHECKED | | |
| FINISH | | DESIGN APPROVED | | |
| APPLICATION | | MFG APPROVED | | |
| DO NOT SCALE DRAWING | | QA APPROVED | | |
| | | RELEASE DATE | 05-28-09 | |
| | | SCALE | NONE | |
| | | SHEET | 1 OF 2 | |
| | | SIZE | C | |
| | | CAGE CODE | DWG. NO. 641-0286 | |
| | | PHONE: (805) 579-0216 | FAX: (805) 579-6005 | |
| | | WEBSITE: www.puroflux.com | | |

PROPRIETARY AND CONFIDENTIAL
THE INFORMATION CONTAINED IN THIS
DRAWING IS THE SOLE PROPERTY OF
PUROFLUX CORPORATION. ANY
REPRODUCTION IN PART OR AS A WHOLE
WITHOUT THE WRITTEN PERMISSION OF
PUROFLUX CORPORATION IS
PROHIBITED.

NOTICE OF PROPRIETARY RIGHTS
 This document contains confidential technical data, including trade secrets, proprietary to Puroflux, Inc. Disclosure of this data to you is expressly conditioned upon your assent that its use is limited to use within your company only (and does not include manufacture or processing uses). Any other use is strictly prohibited without the prior written consent of Puroflux, Inc.

| REVISIONS | | | |
|-----------|-------------------------|----------|----------|
| REV | DESCRIPTION | DATE | APPROVED |
| D | REVISED VALBIA ACTUATOR | 10-21-11 | K.C. |

D

D

C

C

B

B

A

A

4

3

2

1

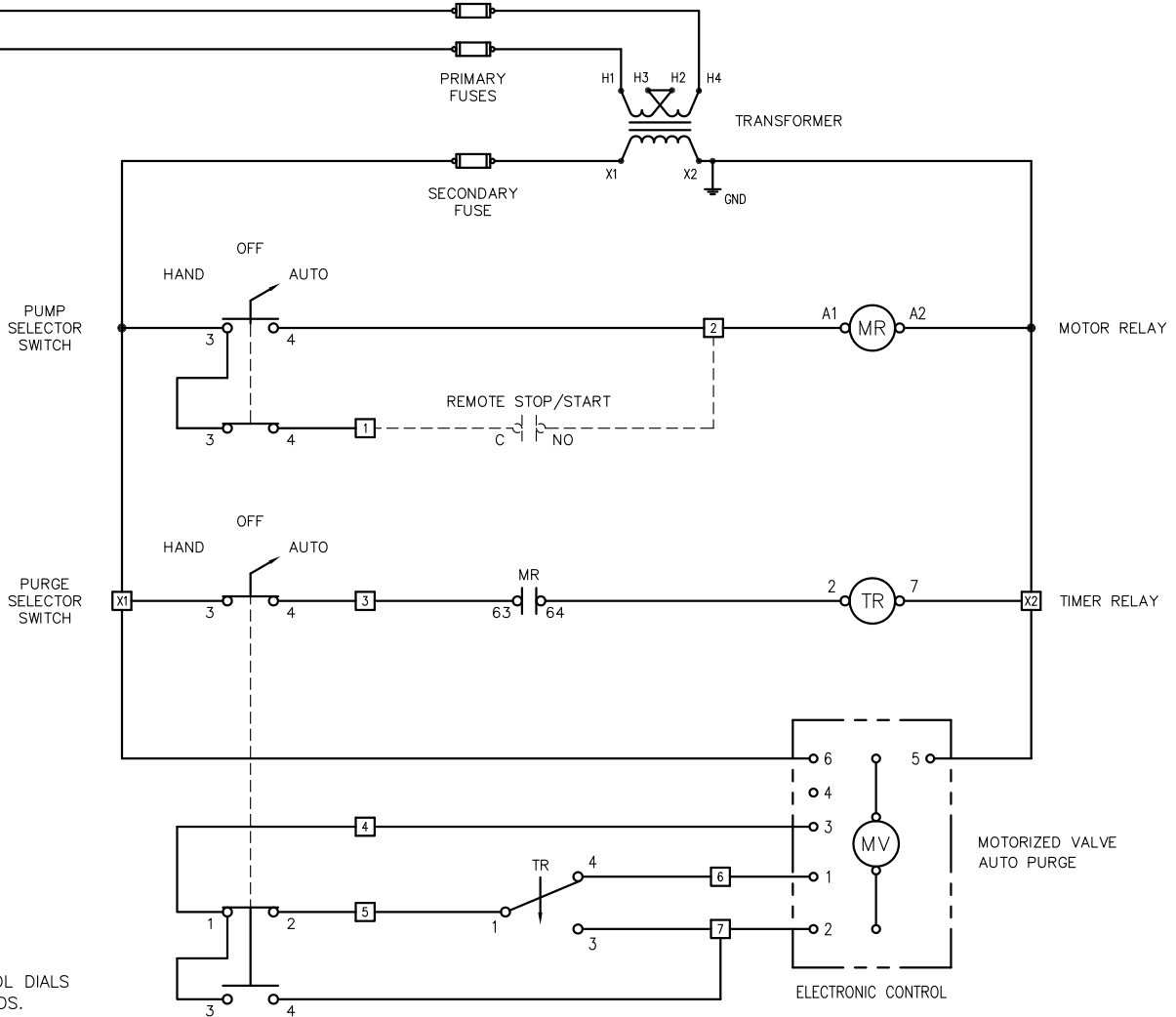
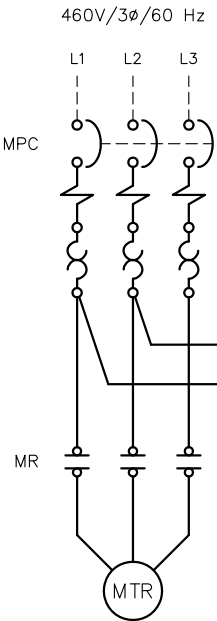

PROGRAMMING

THE PUROFLUX AUTO PURGE TIMER IS EQUIPPED WITH TWO CONTROL DIALS TO PROGRAM THE PURGING CYCLES TO MATCH YOUR SPECIFIC NEEDS.

CYCLE TIME

DIAL UPPER INDICATOR (T1) TO THE DESIRED FREQUENCY OF PURGING
 RANGE : 14 MINUTES TO 24 HOURS
 FACTORY SETTING : 25% (APPROX EVERY 6 HRS)

PURGING TIME

DIAL LOWER INDICATOR (T2) TO THE DESIRED DURATION OF PURGING
 RANGE : 6 TO 60 SECONDS
 FACTORY SETTING : 35% (APPROX 20 SEC)

DWG. NO. 642-0032 SH 1 REV D

| | | | | |
|---------------------------|--|-----------------------|--------------------------------------|--------------|
| MATERIAL | UNLESS OTHERWISE NOTED | PROJ. NO. | WIRING DIAGRAM : 460V/3φ/60 HZ | |
| | DIMENSIONS ARE IN INCHES | DRAWN K. CARTER | AUTO PURGE PANEL : REMOTE STOP/START | |
| | DO NOT SCALE THIS DRAWING | CHECKED | PUROFLUX CORPORATION | |
| | INTERPRET DRAWING PER APPLICABLE STANDARDS | DESIGN APPROVED | | |
| HEAT TREAT | DECIMALS ANGLES SURFACE FINISH | MFG APPROVED | SIZE C | CAGE CODE |
| FINISH | THREADS PER NBS HANDBOOK-H28 | QA APPROVED | DWG NO. | 642-0032 |
| | CONCENTRICITIES .010 TR | RELEASE DATE 08-23-02 | SCALE NONE | REV D |
| NEXT ASSEMBLY APPLICATION | BREAK CORNERS .005-.015 INTERNAL RADI .015-.030 | | | SHEET 1 OF 1 |