

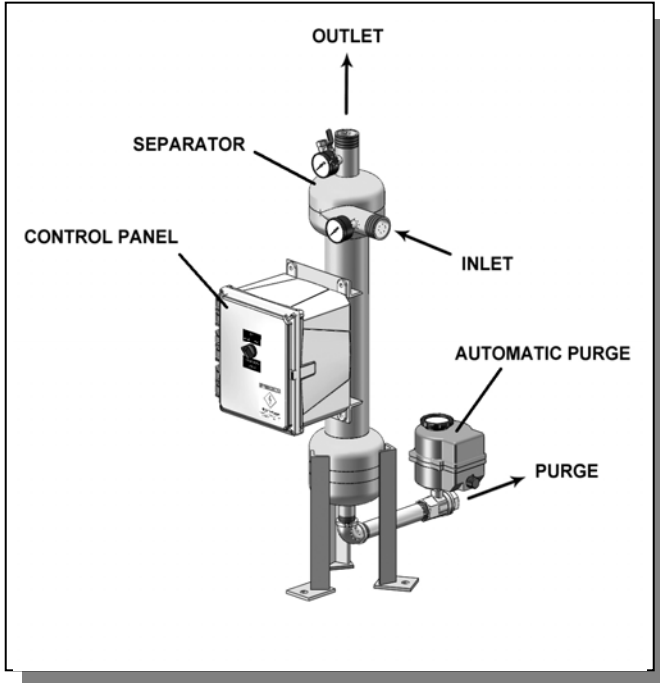

PUROFLUX CORPORATION

ENGINEERING • MANUFACTURING • SERVICE

PF61-020 SPECIFICATION SHEET – 2" THREADED SEPARATOR



SPECIFICATIONS	PF61-020
Flow Range	65-135 gpm
Connections – Influent / Effluent	2" mpt
Purge Outlet	1" fpt
Manual Air Bleed Valve	1/4" fpt
Volume	7 gal
Est. Weight, Dry	74 lbs
Est. Weight, Operating	125 lbs
Options:	
Manual Purge	
Wall Mounting Brackets	
Inspection Port	Consult Factory

- Carbon steel construction
- Fusion bonded polyester coating
- True tangential entry
- 150 psi working pressure
- Industrial grade manual purge valve
- 0 to 160 psi gauges on influent / effluent
- 1/4" manual air bleed valve
- Five year limited warranty

PRESSURE DROP vs. FLOW RATE							
Pressure Drop	3 psi	4 psi	6 psi	8 psi	10 psi	12 psi	CV Factor
Flow (gpm)*	67	77	95	109	122	134	38.6

*(Flow rate / CV values may vary slightly)

To determine the approximate pressure drop at flow rates not shown in this chart, use the following formula:

$$\Delta P = (\text{FLOW RATE} / \text{CV})^2$$

CV Factor : CV is defined as the flow in gallons per minute (GPM) that will produce a one pound pressure drop across the separator.

NOTES: UNLESS OTHERWISE SPECIFIED

1. DIMENSIONS ARE IN INCHES
2. DIMENSIONS MAY VARY SLIGHTLY - DO NOT USE FOR CONSTRUCTION
3. SEPARATOR SYSTEM IS RATED FOR 150 PSI WORKING PRESSURE
4. VESSEL CONSTRUCTION: CARBON STEEL TANK
EPOXY COATED EXTERIOR

REVISIONS			
REV	DESCRIPTION	DATE	APPROVED
C	UPDATED TO SOLIDWORKS	06-12-09	D.L.

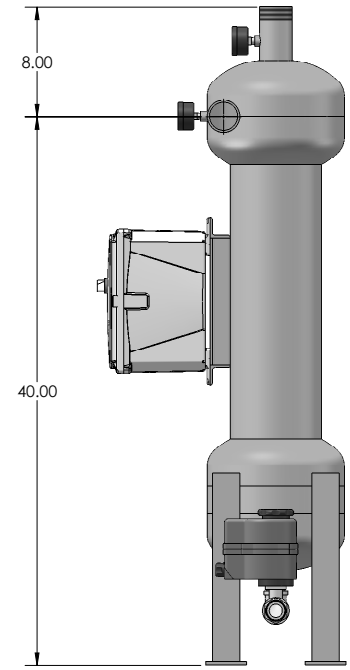
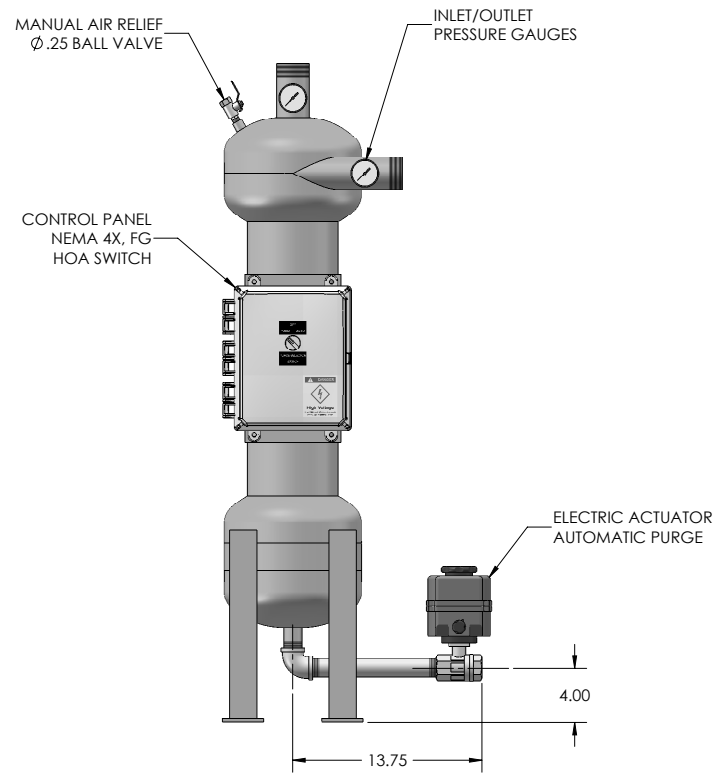
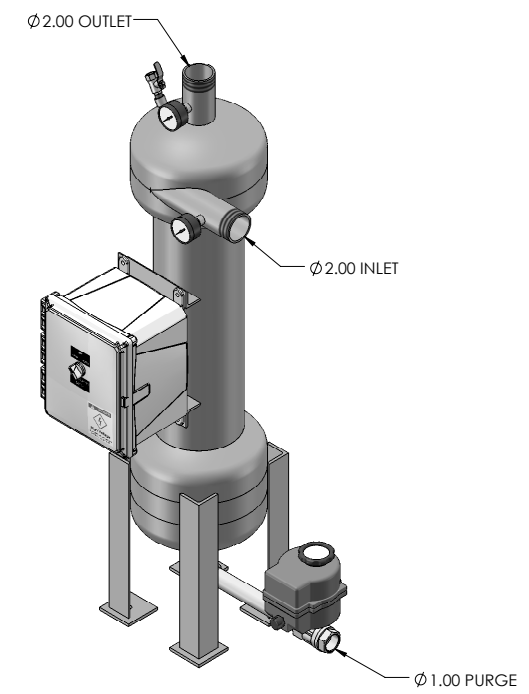
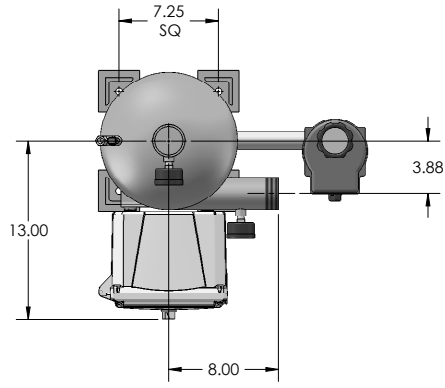

UNLESS OTHERWISE SPECIFIED DIMENSIONS ARE IN INCHES TOLERANCES: FRACTIONAL ± ANGULAR: MACH ± BEND ± TWO PLACE DECIMAL ± THREE PLACE DECIMAL ±		PROJ. NO.	PF61-020-AP HYDROCYCLONE SEPARATOR 65-135 GPM - WITH MTG LEGS	
INTERPRET GEOMETRIC TOLERANCING PER:		DRAWN	K. CARTER	
MATERIAL		CHECKED		
FINISH		DESIGN APPROVED		
APPLICATION		MFG APPROVED		
DO NOT SCALE DRAWING		QA APPROVED		
		RELEASE DATE	02-15-00	
PROPRIETARY AND CONFIDENTIAL THE INFORMATION CONTAINED IN THIS DRAWING IS THE SOLE PROPERTY OF PUROFLUX CORPORATION. ANY REPRODUCTION IN PART OR AS A WHOLE WITHOUT THE WRITTEN PERMISSION OF PUROFLUX CORPORATION IS PROHIBITED.		SCALE	NONE	
		SHEET	1	OF 2

PUROFLUX CORPORATION
 PHONE: (805) 579-0216
 FAX: (805) 579-6005
 WEBSITE: www.puroflux.com

SIZE	CAGE CODE	DWG. NO.	REV
C		611-0144	C

4

3

2

1

NOTICE OF PROPRIETARY RIGHTS

This document contains confidential technical data, including trade secrets, proprietary to Puroflux, Inc. Disclosure of this data to you is expressly conditioned upon your assent that its use is limited to use within your company only (and does not include manufacture or processing uses). Any other use is strictly prohibited without the prior written consent of Puroflux, Inc.

REVISIONS			
REV	DESCRIPTION	DATE	APPROVED
F	REVISED VALBIA WIRING	11-14-11	K.C.

PROGRAMMING

THE PUROFLUX AUTO PURGE TIMER IS EQUIPPED WITH TWO CONTROL DIALS TO PROGRAM THE PURGING CYCLES TO MATCH YOUR SPECIFIC NEEDS.

CYCLE TIME

DIAL UPPER INDICATOR (T1) TO THE DESIRED FREQUENCY OF PURGING
RANGE : 14 MINUTES TO 24 HOURS
FACTORY SETTING : 25% (APPROX EVERY 6 HRS)

PURGING TIME

DIAL LOWER INDICATOR (T2) TO THE DESIRED DURATION OF PURGING
RANGE : 6 TO 60 SECONDS
FACTORY SETTING : 35% (APPROX 20 SEC)

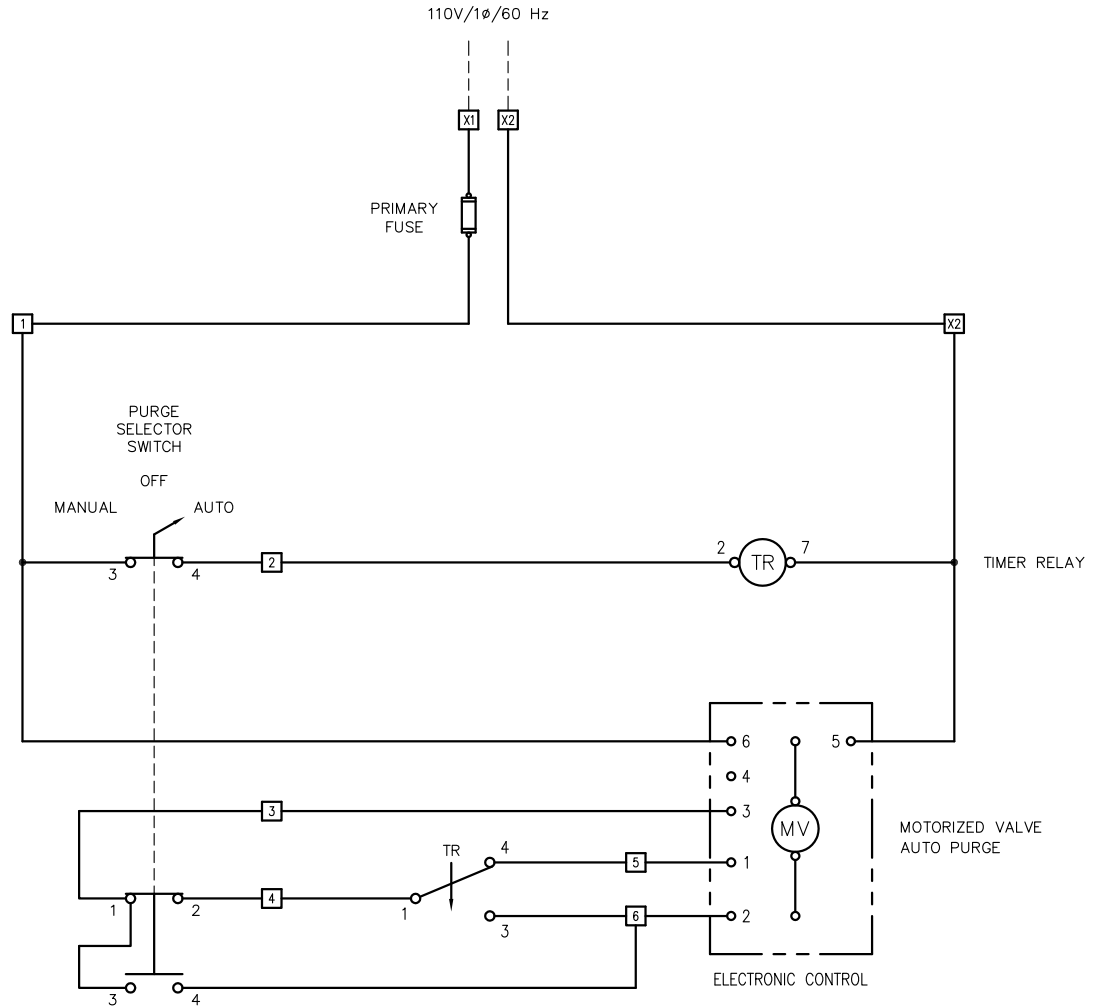

1 ACTUAL WIRING MAY VARY DEPENDING UPON ELECTRIC ACTUATOR MODEL NUMBER

NOTES: UNLESS OTHERWISE SPECIFIED

MATERIAL	UNLESS OTHERWISE NOTED DIMENSIONS ARE IN INCHES DO NOT SCALE THIS DRAWING	PROJ. NO.	WIRING DIAGRAM: 110V/1φ/60 HZ AUTOMATIC PURGE PANEL	
HEAT TREAT	INTERPRET DRAWING PER APPLICABLE STANDARDS	DRAWN	K. CARTER	
FINISH	DECIMALS .XX ± - ± -	CHECKED		
	ANGLES ± - -	DESIGN APPROVED		
NEXT ASSEMBLY	THREADS PER NBS HANDBOOK-H28	MFG APPROVED		
APPLICATION	CONCENTRICITIES .010 TR	QA APPROVED		
	BREAK CORNERS .005-.015	RELEASE DATE	02-01-02	
	INTERNAL RADI .015-.030	SCALE	NONE	
		SIZE	C	
		CAGE CODE		
		DWG. NO.	612-0002	
		REV	F	
		SHEET	1 OF 1	

4

3

2

1

DWG. NO. 612-0002 SH 1 REV F