

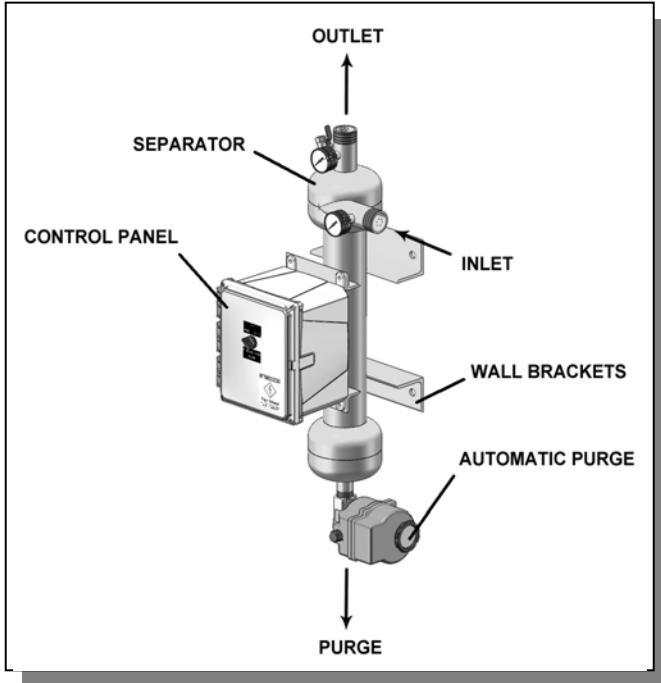

PUROFLUX CORPORATION

ENGINEERING • MANUFACTURING • SERVICE

PF61-015 SPECIFICATION SHEET – 1 1/2” THREADED SEPARATOR



SPECIFICATIONS	PF61-015
Flow Range	50-100 gpm
Connections – Influent / Effluent	1 1/2” mpt
Purge Outlet	1” fpt
Manual Air Bleed Valve	1/4” fpt
Volume	2 gal
Est. Weight, Dry	27 lbs
Est. Weight, Operating	40 lbs
Options:	
Manual Purge	
Mounting Legs	
Inspection Port	Consult Factory

- Carbon steel construction
- Fusion bonded polyester coating
- True tangential entry
- 150 psi working pressure
- Industrial grade manual purge valve
- 0 to 160 psi gauges on influent / effluent
- 1/4” manual air bleed valve
- Five year limited warranty

PRESSURE DROP vs. FLOW RATE							
Pressure Drop	3 psi	4 psi	6 psi	8 psi	10 psi	12 psi	CV Factor
Flow (gpm)*	51	59	72	83	93	102	29.5

*(Flow rate / CV values may vary slightly)

To determine the approximate pressure drop at flow rates not shown in this chart, use the following formula:

$$\Delta P = (\text{FLOW RATE} / \text{CV})^2$$

CV Factor : CV is defined as the flow in gallons per minute (GPM) that will produce a one pound pressure drop across the separator.

4

3

2

1

NOTICE OF PROPRIETARY RIGHTS

This document contains confidential technical data, including trade secrets, proprietary to Puroflux, Inc. Disclosure of this data to you is expressly conditioned upon your assent that its use is limited to use within your company only (and does not include manufacture or processing uses). Any other use is strictly prohibited without the prior written consent of Puroflux, Inc.

REVISIONS			
REV	DESCRIPTION	DATE	APPROVED
C	REVISED FOR VALBIA	09-02-08	K.C.

PROGRAMMING

THE PUROFLUX AUTO PURGE TIMER IS EQUIPPED WITH TWO CONTROL DIALS TO PROGRAM THE PURGING CYCLES TO MATCH YOUR SPECIFIC NEEDS.

CYCLE TIME

DIAL UPPER INDICATOR (T1) TO THE DESIRED FREQUENCY OF PURGING
RANGE : 14 MINUTES TO 24 HOURS
FACTORY SETTING : 25% (APPROX EVERY 6 HRS)

PURGING TIME

DIAL LOWER INDICATOR (T2) TO THE DESIRED DURATION OF PURGING
RANGE : 6 TO 60 SECONDS
FACTORY SETTING : 35% (APPROX 20 SEC)

110V/1 ϕ /60 Hz

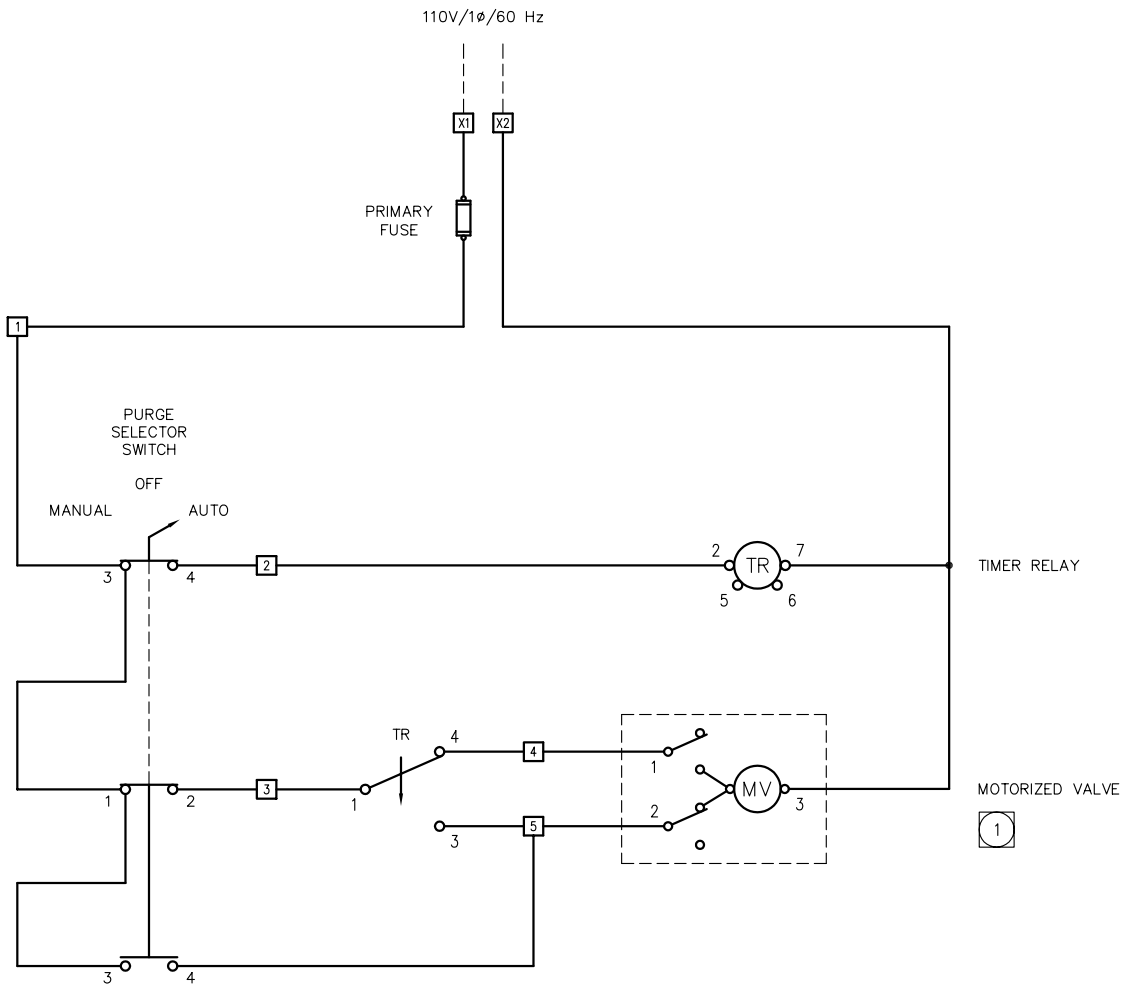

DWG. NO. 612-0002 SH 1 REV C

1 ACTUAL WIRING MAY VARY DEPENDING UPON ELECTRIC ACTUATOR MODEL NUMBER

NOTES: UNLESS OTHERWISE SPECIFIED

MATERIAL	UNLESS OTHERWISE NOTED	PROJ. NO.	WIRING DIAGRAM: 110V/1 ϕ /60 HZ	
HEAT TREAT	DIMENSIONS ARE IN INCHES DO NOT SCALE THIS DRAWING	DRAWN K. CARTER	AUTOMATIC PURGE PANEL	
FINISH	INTERPRET DRAWING PER APPLICABLE STANDARDS	CHECKED	1357 KUEHNER DRIVE SIMI VALLEY CA 93063	
NEXT ASSEMBLY	DECIMALS ANGLES SURFACE FINISH	DESIGN APPROVED	PHONE: (805) 579-0216	
APPLICATION	.XX ± - ± - .XXX ± - -	MFG APPROVED	FAX: (805) 579-6005	
	THREADS PER NBS HANDBOOK-H28	QA APPROVED	SIZE C	CAGE CODE
	CONCENTRICITIES .010 TIR	RELEASE DATE 02-01-02	SCALE NONE	DWG NO. 612-0002
	BREAK CORNERS .005-.015			REV C
	INTERNAL RADI .015-.030			SHEET 1 OF 1

4

3

2

1

A

A

D

D

C

C

B

B

A

A