

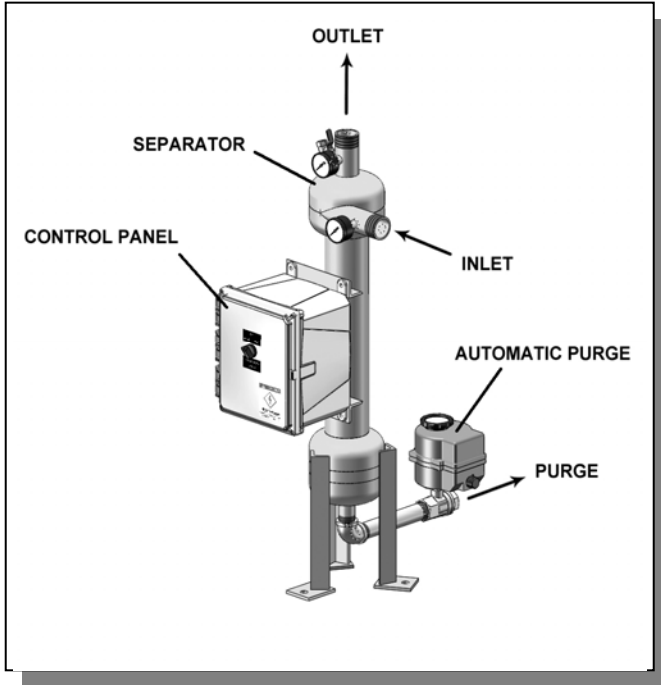

PUROFLUX CORPORATION

ENGINEERING • MANUFACTURING • SERVICE

PF61-015 SPECIFICATION SHEET – 1 1/2” THREADED SEPARATOR



| SPECIFICATIONS | PF61-015 |
|-----------------------------------|-----------------|
| Flow Range | 50-100 gpm |
| Connections – Influent / Effluent | 1 1/2” mpt |
| Purge Outlet | 1” fpt |
| Manual Air Bleed Valve | 1/4” fpt |
| Volume | 2 gal |
| Est. Weight, Dry | 27 lbs |
| Est. Weight, Operating | 40 lbs |
| Options: | |
| Manual Purge | |
| Wall Mounting Brackets | |
| Inspection Port | Consult Factory |

- Carbon steel construction
- Fusion bonded polyester coating
- True tangential entry
- 150 psi working pressure
- Industrial grade manual purge valve
- 0 to 160 psi gauges on influent / effluent
- 1/4” manual air bleed valve
- Five year limited warranty

| PRESSURE DROP vs. FLOW RATE | | | | | | | |
|-----------------------------|-------|-------|-------|-------|--------|--------|-----------|
| Pressure Drop | 3 psi | 4 psi | 6 psi | 8 psi | 10 psi | 12 psi | CV Factor |
| Flow (gpm)* | 51 | 59 | 72 | 83 | 93 | 102 | 29.5 |

*(Flow rate / CV values may vary slightly)

To determine the approximate pressure drop at flow rates not shown in this chart, use the following formula:

$$\Delta P = (\text{FLOW RATE} / \text{CV})^2$$

CV Factor : CV is defined as the flow in gallons per minute (GPM) that will produce a one pound pressure drop across the separator.

NOTES: UNLESS OTHERWISE SPECIFIED

1. DIMENSIONS ARE IN INCHES
2. DIMENSIONS MAY VARY SLIGHTLY - DO NOT USE FOR CONSTRUCTION
3. SEPARATOR SYSTEM IS RATED FOR 150 PSI WORKING PRESSURE
4. VESSEL CONSTRUCTION: CARBON STEEL TANK
EPOXY COATED EXTERIOR

| REVISIONS | | | |
|-----------|-----------------------|----------|----------|
| REV | DESCRIPTION | DATE | APPROVED |
| A | UPDATED TO SOLIDWORKS | 06-15-09 | D.L. |

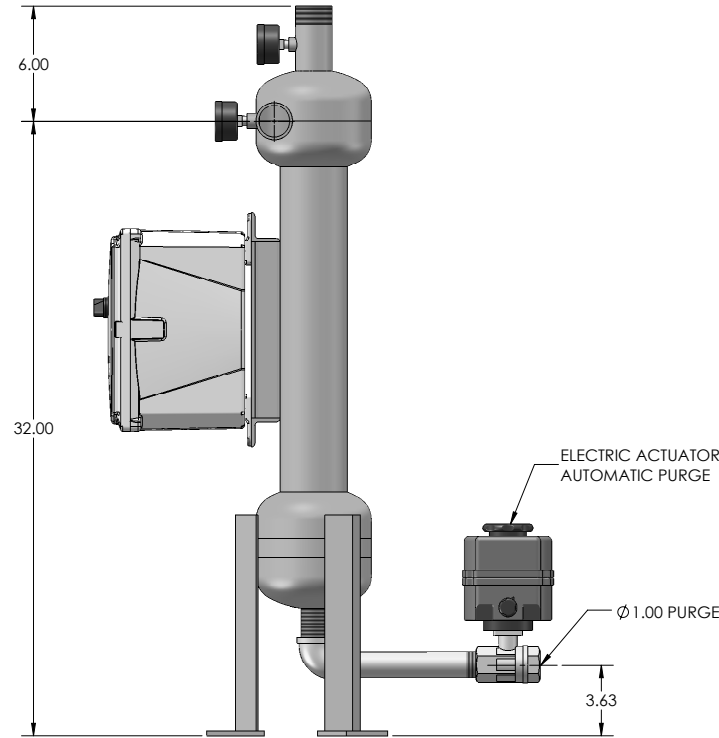
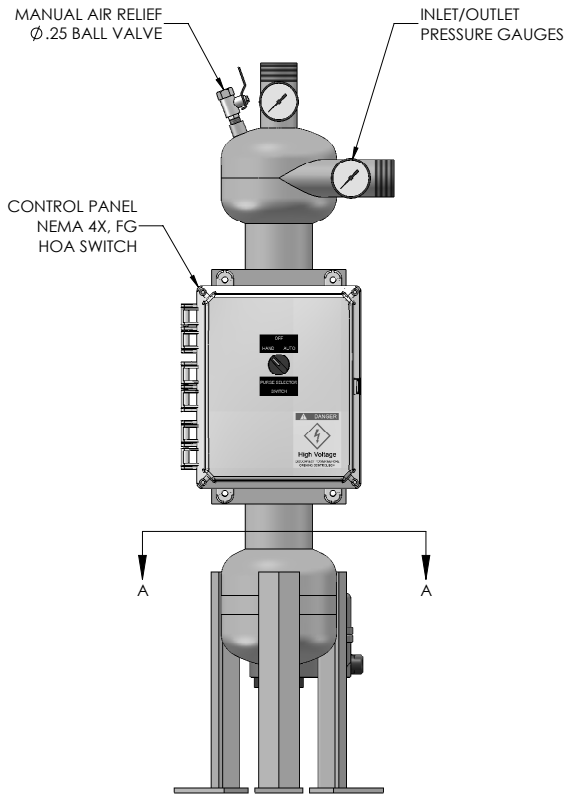
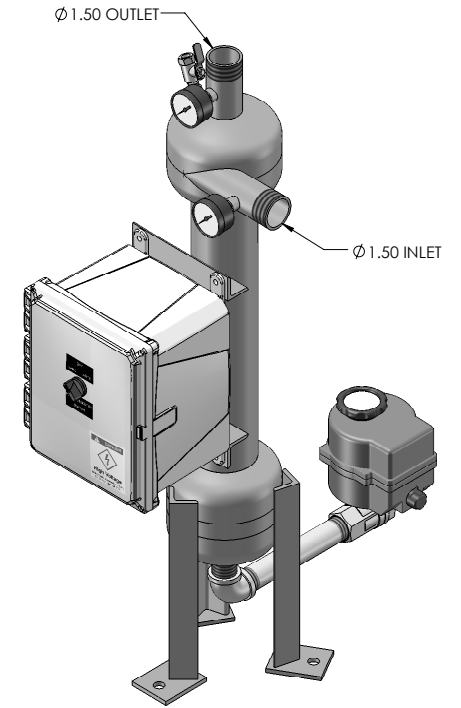
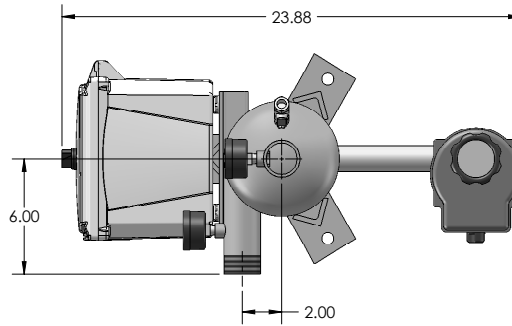

| | | | |
|--|--|--------------------|---|
| PROPRIETARY AND CONFIDENTIAL THE INFORMATION CONTAINED IN THIS DRAWING IS THE SOLE PROPERTY OF PUROFLUX CORPORATION. ANY REPRODUCTION IN PART OR AS A WHOLE WITHOUT THE WRITTEN PERMISSION OF PUROFLUX CORPORATION IS PROHIBITED. | UNLESS OTHERWISE SPECIFIED DIMENSIONS ARE IN INCHES | PROJ. NO. | PF61-015-AP HYDROCYCLONE SEPARATOR |
| | TOLERANCES: FRACTIONAL: ± ANGULAR: MACH ± BEND ± TWO PLACE DECIMAL ± THREE PLACE DECIMAL ± | DRAWN K. CARTER | 50-100 GPM - WITH MTG LEGS |
| | INTERPRET GEOMETRIC TOLERANCING PER: | CHECKED | PHONE: (805) 579-0216 FAX: (805) 579-4005 WEBSITE: www.puroflux.com |
| | MATERIAL | DESIGN APPROVED | SIZE C |
| NEXT ASSY | MFG APPROVED | QA APPROVED | CAGE CODE |
| APPLICATION | FINISH | RELEASE DATE | DWG NO. 611-0143 |
| DO NOT SCALE DRAWING | | 02-18-00 | REV A |
| | | SCALE NONE | SHEET 1 OF 2 |

4

3

2

1

NOTICE OF PROPRIETARY RIGHTS

This document contains confidential technical data, including trade secrets, proprietary to Puroflux, Inc. Disclosure of this data to you is expressly conditioned upon your assent that its use is limited to use within your company only (and does not include manufacture or processing uses). Any other use is strictly prohibited without the prior written consent of Puroflux, Inc.

| REVISIONS | | | |
|-----------|-----------------------|----------|----------|
| REV | DESCRIPTION | DATE | APPROVED |
| F | REVISED VALBIA WIRING | 11-14-11 | K.C. |

PROGRAMMING

THE PUROFLUX AUTO PURGE TIMER IS EQUIPPED WITH TWO CONTROL DIALS TO PROGRAM THE PURGING CYCLES TO MATCH YOUR SPECIFIC NEEDS.

CYCLE TIME

DIAL UPPER INDICATOR (T1) TO THE DESIRED FREQUENCY OF PURGING
RANGE : 14 MINUTES TO 24 HOURS
FACTORY SETTING : 25% (APPROX EVERY 6 HRS)

PURGING TIME

DIAL LOWER INDICATOR (T2) TO THE DESIRED DURATION OF PURGING
RANGE : 6 TO 60 SECONDS
FACTORY SETTING : 35% (APPROX 20 SEC)

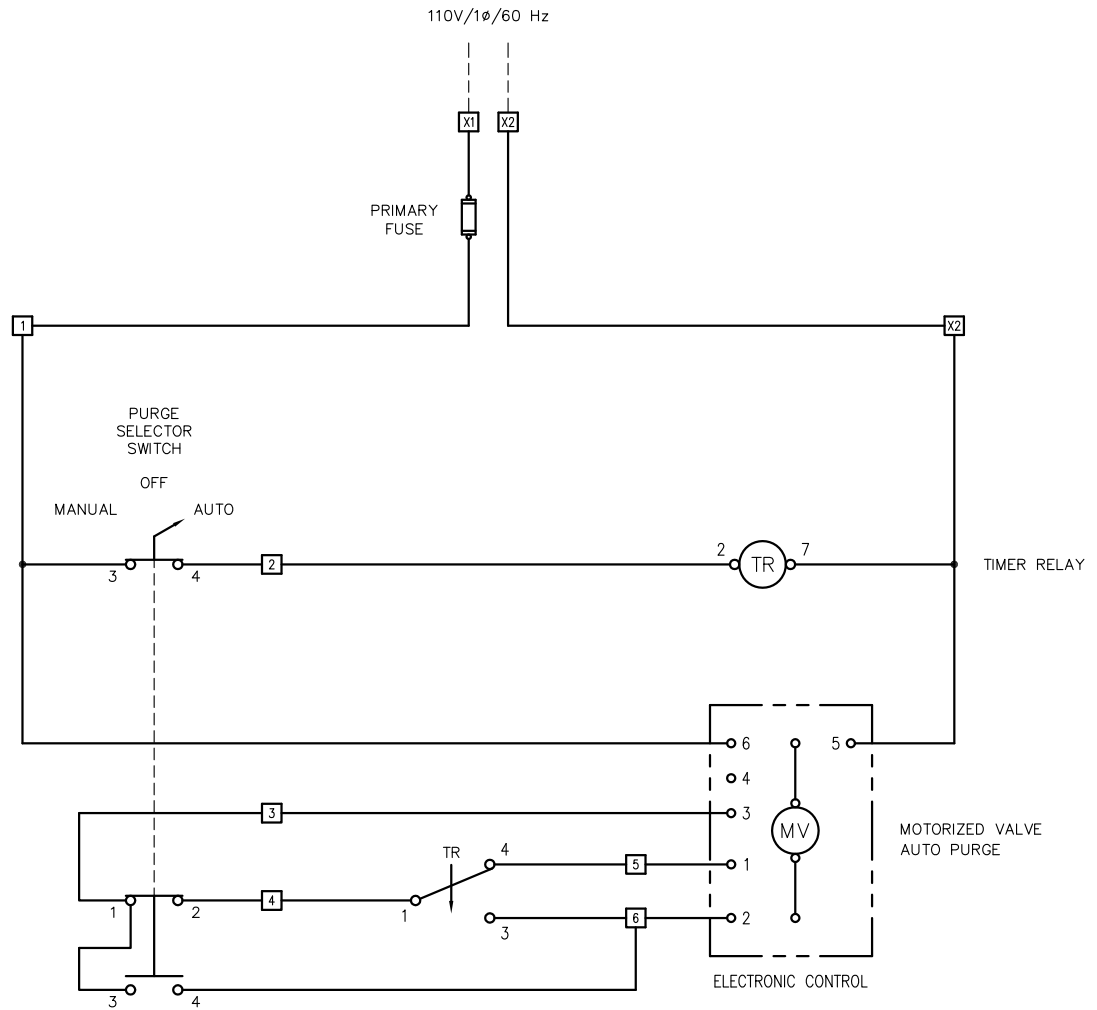

1 ACTUAL WIRING MAY VARY DEPENDING UPON ELECTRIC ACTUATOR MODEL NUMBER

NOTES: UNLESS OTHERWISE SPECIFIED

| | | | | |
|---------------|---|-----------------|--|--|
| MATERIAL | UNLESS OTHERWISE NOTED DIMENSIONS ARE IN INCHES DO NOT SCALE THIS DRAWING | PROJ. NO. | WIRING DIAGRAM: 110V/1φ/60 HZ AUTOMATIC PURGE PANEL | |
| HEAT TREAT | INTERPRET DRAWING PER APPLICABLE STANDARDS | DRAWN | K. CARTER | |
| FINISH | DECIMALS .XX ± - ± - | CHECKED | | |
| | ANGLES ± - - | DESIGN APPROVED | | |
| NEXT ASSEMBLY | THREADS PER NBS HANDBOOK-H28 | MFG APPROVED | | |
| APPLICATION | BREAK CORNERS .005-.015 | QA APPROVED | | |
| | INTERNAL RADI .015-.030 | RELEASE DATE | 02-01-02 | |
| | | SCALE | NONE | |
| | | SIZE | C | |
| | | CAGE CODE | | |
| | | DWG. NO. | 612-0002 | |
| | | REV | F | |
| | | SHEET | 1 OF 1 | |

4

3

2

1

DWG. NO. 612-0002 SH 1 REV F